

# Marvin Connected Home Casement and Awning Wiring Instructions

---

**ABSTRACT:** These instructions are intended for an electrician to properly wire low voltage power to the windows after they have been properly installed. If anything requires removal of installation screws or shims to run wire, please check with the general contractor to ensure that no critical installation components will be damaged.

**Usage Dates:** August 8, 2025 to present. Note: if you have product produced before August 8, 2025 use the section, [Pre-8/2025 Wiring Instructions on page 12](#).

**Relevant Products:**

- Modern Automated Casement
- Modern Automated Awning

## Table of Contents

---

<a href="#">Tools Needed</a> .....	1	<a href="#">Switch Wiring Examples</a> .....	8
<a href="#">Pull Wire into the Window</a> .....	2	<a href="#">Wiring Multiple Windows to a Single Switch</a> .....	9
<a href="#">Wire the Power</a> .....	4	<a href="#">Dry Contact Functionality</a> .....	10
<a href="#">Connecting to WiFi or Ethernet (optional)</a> .....	7	<a href="#">Marvin Power Supply</a> .....	11
<a href="#">Wire an Optional Switch</a> .....	8	<a href="#">Pre-8/2025 Wiring Instructions</a> .....	12

## Tools Needed

- Wire stripper
- 3/32" (2.5) flat bladed screwdriver
- Power drill

## Pull Wire into the Window

1. Pull all necessary wire into the window frame. Power wire needs to support 1 Amp of 24Vdc (16 ga. wire is recommended.) Figure 1 and Figure 3 show the location of the pre-drilled holes in the window frame to run power to the control board. Choose one or more of the locations, then drill a 1/4" hole through the rough opening. The drill bit will fit through the pre-drilled frame hole and then may need to penetrate plastic shims, this is normal. When running the wires, use wiring methods that are compliant with all local, applicable codes and practices. See Figure 1

### IMPORTANT

If one of the holes shown in location 3 on Figure 1 is used, ensure wire jacketing is not punctured or torn when pulling through the frame. If necessary, use small wire tie downs to ensure the wire runs along the frame and will not interfere with the interior covers when installed. See Figure 1 and in Modern Installation Instructions.

### IMPORTANT

Wire runs coming into the frame from locations away from the main control board may be visible from the exterior when the window is open so choosing a black jacketed wire will be the best aesthetic choice.

2. If desired, wire can be run to connect the dry contact terminals to a 3rd-party switch or other control mechanism. Use the pre-drilled hole locations shown in Figures 1 and 2 to run the wire. Cat5 or Cat6 wire is suggested for dry contact wiring.



## WARNING!

Avoid drilling additional holes into the window frame if possible. If a hole is needed, use a regular twist drill bit and a medium drill speed. Do not use an impact driver or hammer drill.

**NOTE:** Marvin suggests the use of 16/2 copper wire to power the windows. To operate optimally, the nominal voltage should be 24VDC, minimum 21.5VDC, at the window.

**NOTE:** The power source must be a Class 2 type with limited voltage and current defined in Article 725 of the US National Electrical Code (NEC).

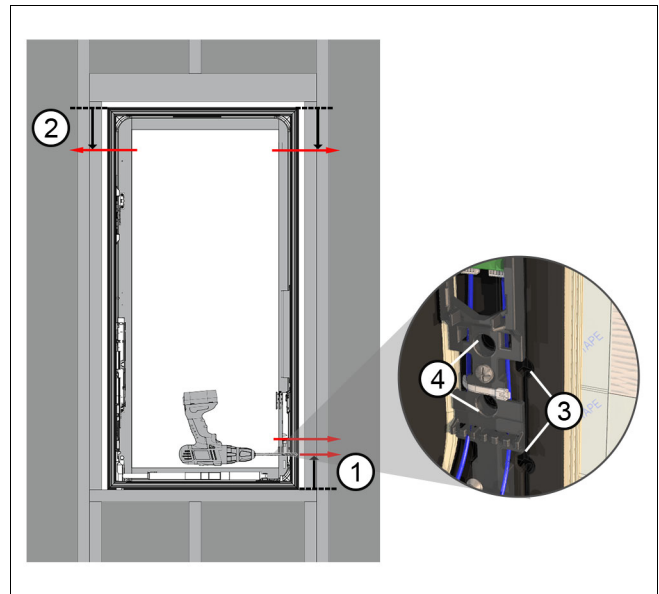

Figure 1 Casement: red arrows denote factory installation holes.

1	Wiring holes 3.7" from the bottom of the frame
2	Wiring holes 2.8" from the top of the frame
3	Through jamb installation holes
4	Wiring holes

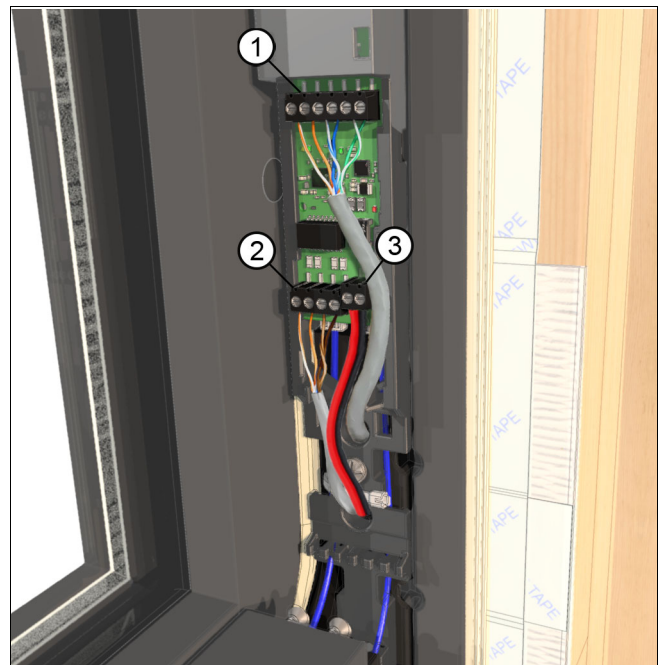
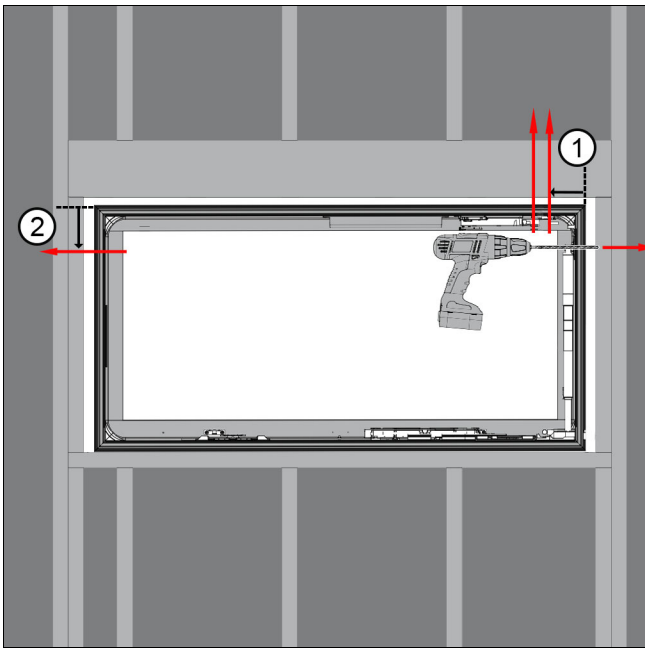

Figure 2

1	Dry contacts for optional wall switch
2	Ethernet connection
3	24Vdc power



**Figure 3 Awning: red arrows denote factory installation holes.**

1	Wiring holes 3.7" from the side of the frame
2	Wiring holes 2.8" from the top of the frame

## Wire the Power

1. There are 12 wiring terminals on the control board located on the hinge-side of the unit (hinge is on top for awnings).

**NOTE:** Terminal block allows #16-30 AWG, stranded or solid copper. Insulation should be stripped to 1/4". Terminals should be tightened with 2 in-lbs torque.



Figure 4 Terminal block cover is removed in this image.

**NOTE:** The board will shut down when voltage exceeds 26.7Vdc or current exceeds 4.5A, so even though power is still coming in the control board will shut down if it gets too high. After a shutdown due to a spike, voltage will have to drop below 24.9Vdc for the board to restart. There is a red LED located by the wiring terminals that will remain illuminated under this condition.

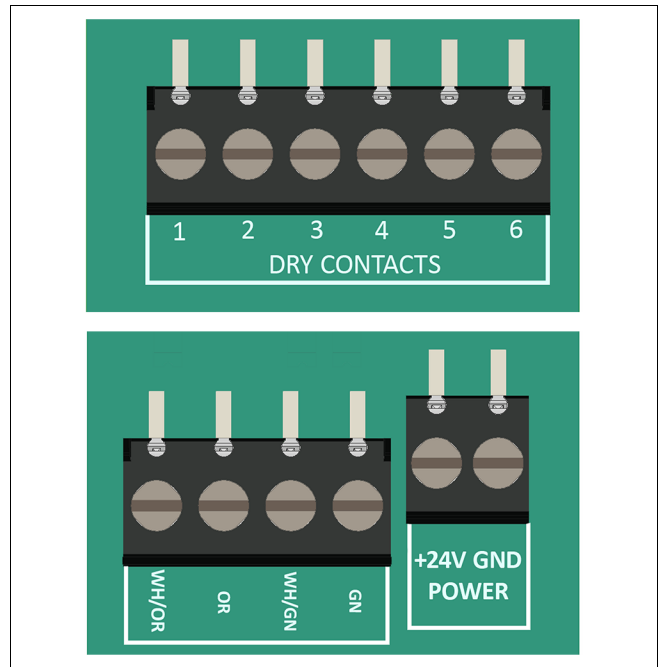

Figure 5

Table 1

Terminal	Description
1	Closes and locks the window
2	Position 1 (about 1" opening)
3	Position 2 (about 4" opening)
4	Position 3- defaults to max opening
5	Stops window sash at current position
6	Switch common
WH/OR	White/Orange Ethernet (TX+)
OR	Orange Ethernet (TX-)
WH/GN	White/Green Ethernet (RX+)
GN	Green Ethernet (RX-)
+24Vdc	Hot from 24Vdc supply
GND	Ground from 24Vdc supply

2. Refer to [Figure 6](#) and see [Table 2, "Button Press Functions"](#) for the following:

- Once power is supplied to the unit, the lock motors will calibrate and move to a home position. The window can then be tested by pressing the "up" button on the small switch located near the control board.
- Pressing the "up" button will unlock and open the window.
- Pressing the "down" button will close and re-lock the window. The window will only open to about 4 inches when first powered.
- For maximum opening, recalibrate the window by pressing down and the reset/pair button simultaneously and let go. If successful, the LED on the switch will alternate red and green while the window calibrates itself. If the window does not go into calibration mode, repeat simultaneously pressing both buttons until you see red and green alternating on the LED

 **Tip**

The reset/pair button is only accessible with a small pin like a paperclip. Be sure to guide the pin perpendicular to the access hole so the button is pressed. You will feel a positive detent when the button is pressed. When holding the pinhole button down for 5, 15 or 30 seconds, the window will beep once, twice or thrice after the corresponding amount of time has elapsed.

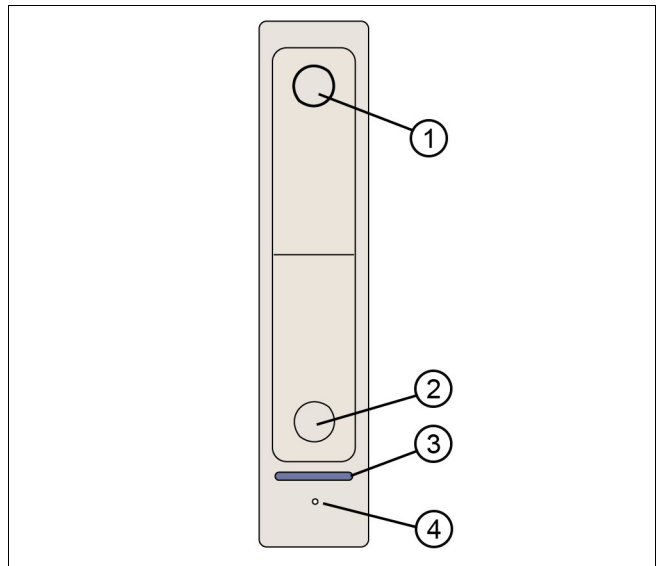

**Figure 6**

1	Up button, press once to open
2	Down button, press once to close and lock
3	Diagnostic LED
4	Reset/pair button (pinhole access)

**Table 2 Button Press Functions**

Function	Button Press	LED
Open to Max Position	Press the "UP" button.	Pulse light green
Stop sash	While the sash is moving, press either the "UP" or "DOWN" button.	Nothing
Close and Lock	Press the "DOWN" button once	Pulse light green
Move sash without obstruction detection	Press and hold "UP" or "DOWN" button.	Nothing
Reboot	Press "UP" 3 times then "DOWN" 3 times (4 beeps)	Single blue flash
Calibrate motors	Press "DOWN" + "RESET/PAIR"	Flash red/green
Factory Reset	Hold "RESET/PAIR" button for 30 seconds	Nothing

*NOTE: Factory reset: all WiFi information is deleted. You will need to update WiFi credentials to re-establish a connection.*

*NOTE: Reboot may fix any operational or WiFi connectivity issues.*

**Table 3**

<b>Diagnostic LED</b>
Off = Normal
Alternating green/red = Calibrating motors
Pulse red 3x = Obstruction detected
Solid red = Power from backup
Pulse light green = Sash is moving
Pulse blue = Moisture detected
Alternating dark blue/light blue = pairing mode
Pulse yellow = Motor homing sequence

---

## Connecting to WiFi or Ethernet (optional)

1. If connecting the windows to Ethernet or WiFi, network security settings may prevent connection to the Marvin cloud. Under higher security settings port 8883 may be blocked and would prevent the connection so router settings would need to change to allow the connection. Due to space constraints, the controller must be wired to Ethernet by stripping 2 of the pairs in the Ethernet cable and terminating them under the screw terminals. Assuming the network follows the T568B standard, wire the white/orange, orange, white/green and green wires to each of the 4 terminals from left to right as labeled on the control board as well as the associated label. This will result in 10/100 Ethernet so ensure the network switch is capable of those speeds. See [Figure 7](#).

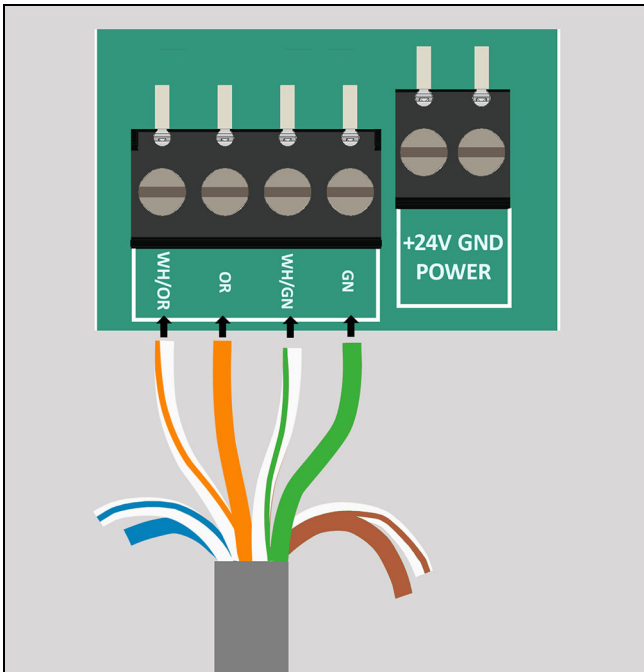

Figure 7

2. Alternatively you can connect the window to a 2.4GHz, password protected WiFi network. The Marvin Home app can be downloaded from the Apple App store or Google Play store. To put the window into pairing mode, press and release the "RESET/PAIR" button in the on-window switch with a small paperclip and then pair it to your mobile device to enter WiFi credentials. For more details, refer to the [Connected Home User Guide](#).

## Wire an Optional Switch

1. Wired switches control the window by temporarily connecting one of terminals 1-5 with the switch common on terminal 6 of the window controller. Any momentary switch rated for at least 3 volts and 25mA can be used. The window controller does not provide power to illuminate any switch LEDs.

**NOTE:** The “common” terminal of a wall switch is connected to terminal 6 of the window. When a button of a wall switch is pressed and released, one of the connections between terminals 1-5 and terminal 6 is made, and the window takes action. The window only moves when the button is released.

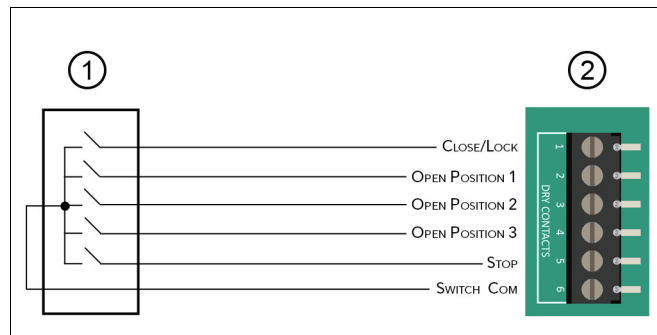

Figure 8

1	Wall switch
2	Window Terminals

## Switch Wiring Examples

**1. 4 Button Switch Example:** This switch connects one of its 1-4 terminals to its “SC” terminal when the associated button is pressed. This will result in a switch that will control the window to 3 different open positions when pressing one of the top 3 buttons or to close and lock when pressing the bottom button. See Figure 9.

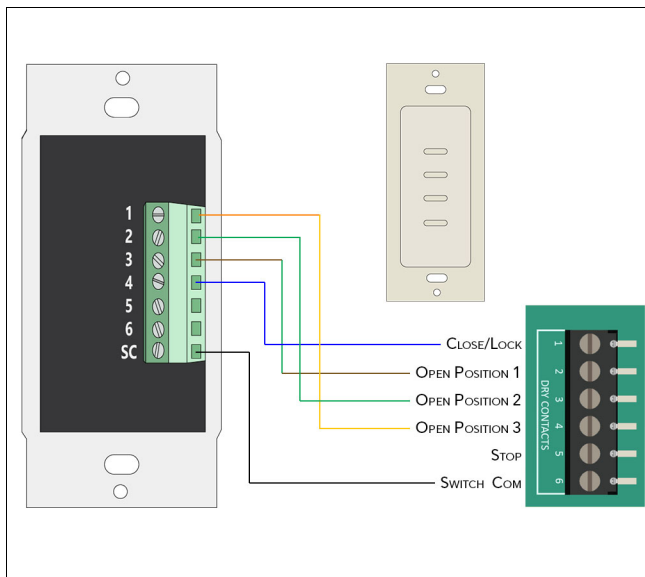

Figure 9

**2. 3 Button Switch Example:** This switch connects one of its 1, 2 or 3 terminals to its “SC” terminal when the associated button is pressed. This will result in a switch that will control the window to an open position when pressing the top button, a smaller opening when pressing the middle button or close and lock when pressing the bottom button. See Figure 10.

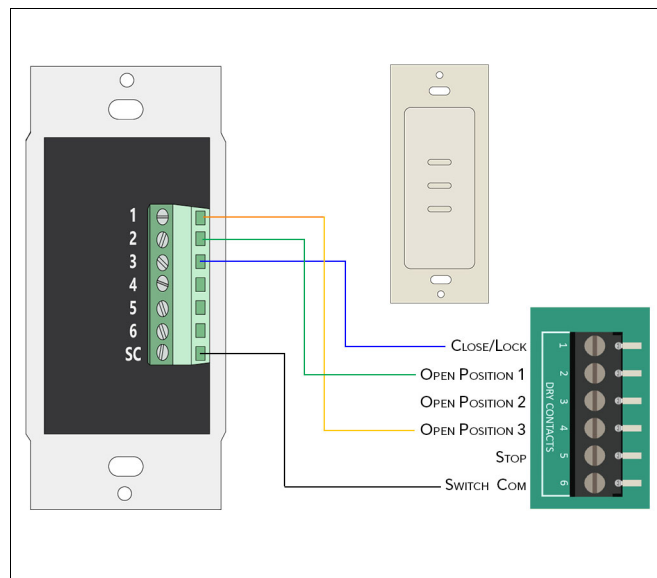

Figure 10

## Wiring Multiple Windows to a Single Switch

1. This example shows three windows being wired to a single switch with 3 dry contact push buttons. Wired as shown, each of the top two buttons on the switch will open the windows to a different open position and the bottom button will close and lock the windows. There is no limit to how many window's dry contact terminals can be wired to a switch, but wire gauge will have an impact after about 1000 feet if the recommended Cat6e is used for the switch wire. The wiring shown is daisy chained from the terminals of one window to the next. This will result in the switch making the same contact closure for all windows simultaneously. Alternatively, a home run could be made to each window giving the flexibility to easily rewire the windows into different configurations at the switch in the future.

*NOTE: If the windows wired to a single switch are of various sizes or types, the position to which they open will be slightly different due to various pivot points of the hardware.*

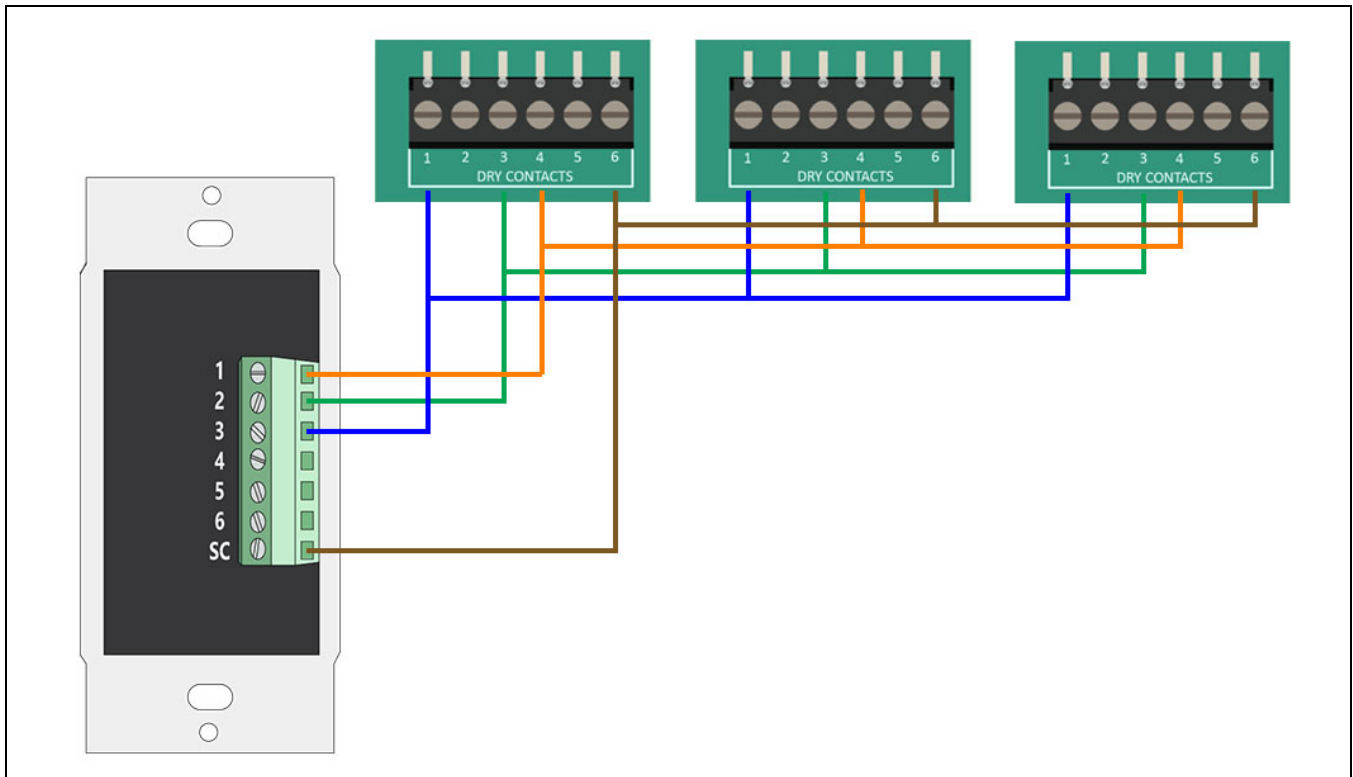

Figure 11

Table 4 Multiple windows to single switch

Switch Wiring Terminals	
Terminal	Description
1	Top Button
2	Middle Button
3	Bottom Button
4	Unused
5	Unused
6	Unused

Window Terminal Designations	
Terminal	Description
1	Closes and locks the window
2	Position 1 (about 1" opening)
3	Position 2 (about 4" opening)
4	Position 3- defaults to max opening
5	Stops window sash at current position
6	Switch common

# Dry Contact Functionality

Table 5

Action	Dry Contact Pins				
	Close and Lock (short pin 6 to 1)	Open position 1 (short pin 6 to 2)	Open position 2 (short pin 6 to 3)	Open position 3 (short pin 6 to 4)	Stop (short pin 6 to 5)
Short Press	Close	Opens to position 1 (10 deg. default)	Opens to position 2 (20 deg default)	Opens to position 3 (max default)	Window stops
Hold 5 sec. (window will beep once after 5 sec.)	Pairing mode (window beeps once again)	Sets position 1 to current position	Sets position 2 to current position	Sets position 3 to current position	No Action
Hold 10 sec. (window beeps once after 5 sec and twice after 10 sec.)	Reboot (Window beeps 4 times)	No Action	No Action	Recalibrate (window will open and close)	No Action

# Marvin Power Supply

## ATTENTION

Each window requires 1 Amps at 24VDC. The voltage at the window must not exceed 26.5V. It is not required to use the power supply sold by Marvin. If a non-Marvin power supply is used, the power source must be a Class 2 type with limited voltage and current defined in Article 725 of the US National Electrical Code (NEC).

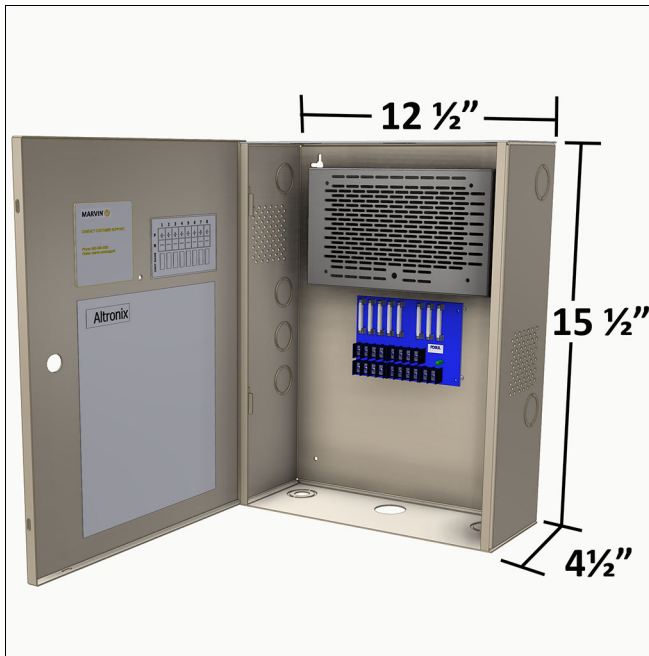

**Figure 12** Wall mounted for indoor use. 1 1/8" and 1 3/8" combo knockouts. Provides 8 fused 24Vdc circuits. Product weight 9.5 lbs. Part Number: 02066143

The Marvin power supply has eight PTC fused terminals. Each terminal can support up to 2.5 amps of current.

When a PTC fuse has more than 2.5A of current flowing through it, the fuse heats up and opens the circuit for protection. The fuse will automatically reset and close a few seconds later when it cools down.

# Pre-8/2025 Wiring Instructions

The instruction on the following pages should be used on Automated Modern Casements and Awnings produced before August 8, 2025. These products have a control board with green wiring terminal blocks. The instructions for wiring those units are nearly identical but the next pages contain the original wiring instructions.

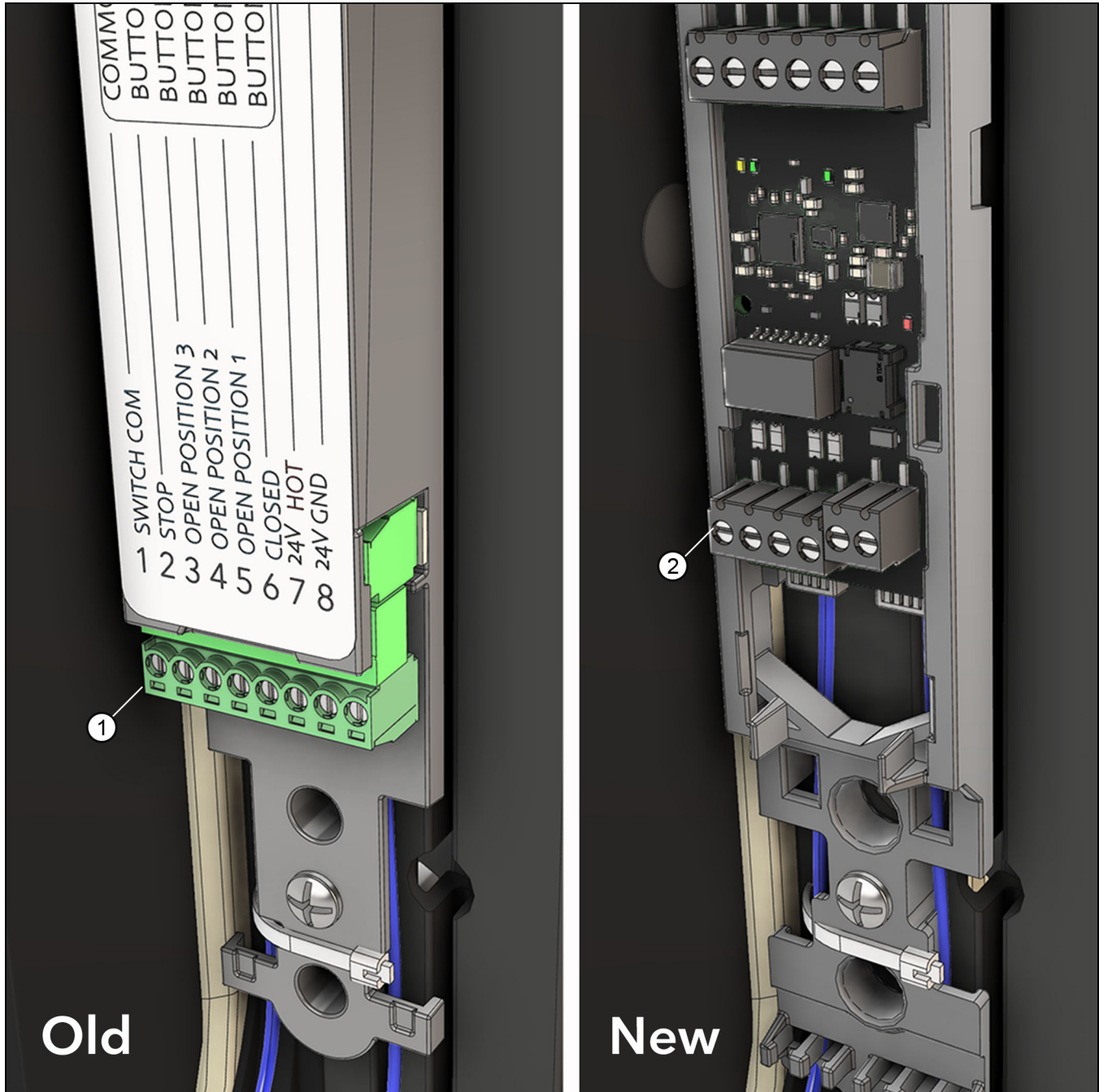

Figure 13

1	Pre- 8/8/2025 control board: has green terminal blocks and can only connect to a network via WiFi
2	Post 8/8/2025 control board: has black terminal blocks and connect to a network via WiFi OR hard wired Ethernet.

# Marvin Connected Home Casement and Awning

## Wiring Instructions

---

**ABSTRACT:** These instructions are intended for an electrician to properly wire low voltage power to the windows after they have been properly installed. If anything requires removal of installation screws or shims to run wire, please check with the general contractor to ensure that no critical installation components will be damaged.

### Relevant Products:

- Modern Automated Casement
- Modern Automated Awning

**Usage Dates:** February 2024 to present.

## Table of Contents

---

Tools Needed .....	1	Switch Wiring Examples .....	5
Pull Wire into the Window .....	2	Wiring Multiple Windows to a Single Switch .....	6
Wire the Power .....	3	Marvin Power Supply .....	7
Wire an Optional Switch .....	5		

## Tools Needed

- Wire stripper
- 3/32" (2.5) flat bladed screwdriver
- Power drill
- 1/4" drill bit (long enough to drill through the window frame and into the rough opening)

## Pull Wire into the Window

1. Pull all necessary wire into the window frame. Power wire needs to support 1 Amp of 24Vdc (16 or 18ga. wire is recommended.) [Figure 1](#) and [Figure 2](#) show the location of the pre-drilled holes in the window frame to run power to the control board. Choose one of the locations, then drill a 1/4" hole through the rough opening. The drill bit will fit through the pre-drilled frame hole and then may need to penetrate plastic shims, this is normal. When running the wires, use wiring methods that are compliant with all local, applicable codes and practices. See [Figure 1](#)

### IMPORTANT

If one of the holes shown in location 3 on [Figure 1](#) is used, ensure wire jacketing is not punctured or torn when pulling through the frame. If necessary, use small wire tie downs to ensure the wire runs along the frame and will not interfere with the interior covers when installed. See [Figure 1](#) and in Modern Installation Instructions.

2. If desired, wire can be run to connect the dry contact terminals to a 3rd-party switch of other control mechanism. Use the pre-drilled hole locations shown in Figures 1 and 2 to run the wire. Cat5 or Cat6 wire is suggested for dry contact wiring. .

### WARNING!

Avoid drilling additional holes in the window frame. If absolutely necessary to drill the frame, contact Marvin for guidance on the proper bit and technique.

*NOTE: Marvin suggests the use of 16/2 copper wire to power the windows. To operate optimally, the nominal voltage should be 24VDC, minimum 21.5VDC, at the window.*

*NOTE: The power source must be a Class 2 type with limited voltage and current defined in Article 725 of the US National Electrical Code (NEC).*

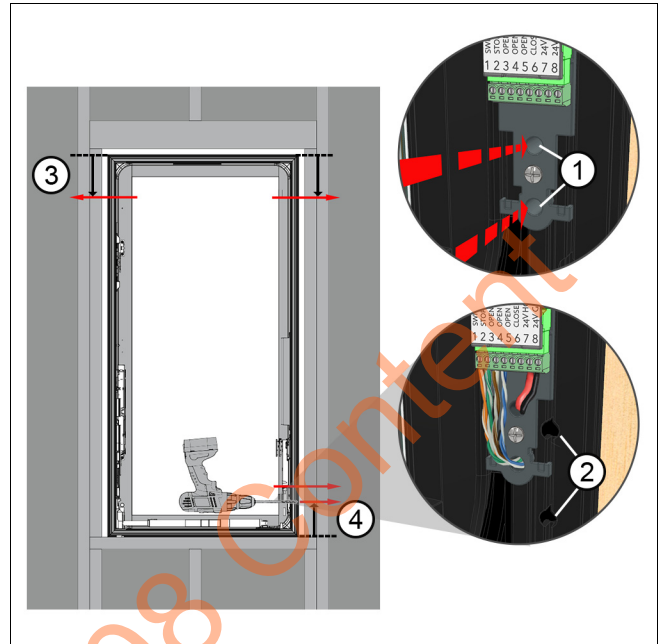

**Figure 1 Casement: red arrows denote factory installation holes.**

1	Wiring holes 3.7" from the bottom of the frame
2	Wiring holes 2.8" from the top of the frame
3	Through jamb installation holes

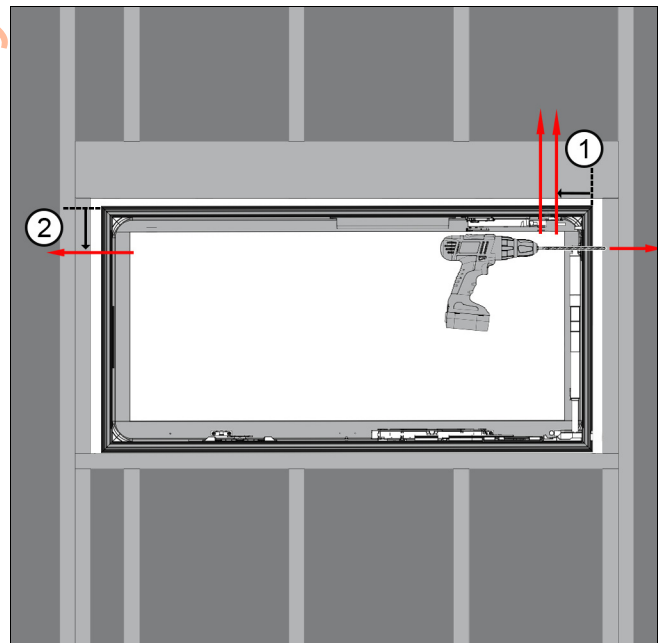

**Figure 2 Awning: red arrows denote factory installation holes.**

1	Wiring holes 3.7" from the side of the frame
2	Wiring holes 2.8" from the top of the frame

## Wire the Power

1. There are 8 wiring terminals at the control board located on the hinge-side of the unit (hinge is on top for awnings). Terminals 7 and 8 are for 24Vdc hot (+) and ground (-) respectively. Terminals 1-6 are dry contacts, intended for use with a wired switch or other automation hardware.

**NOTE:** Terminal block allows #16-30 AWG, stranded or solid copper. Insulation should be stripped to 1/4". Terminals should be tightened with 2 in-lbs torque.



Figure 3 Terminal block cover is removed in this image.

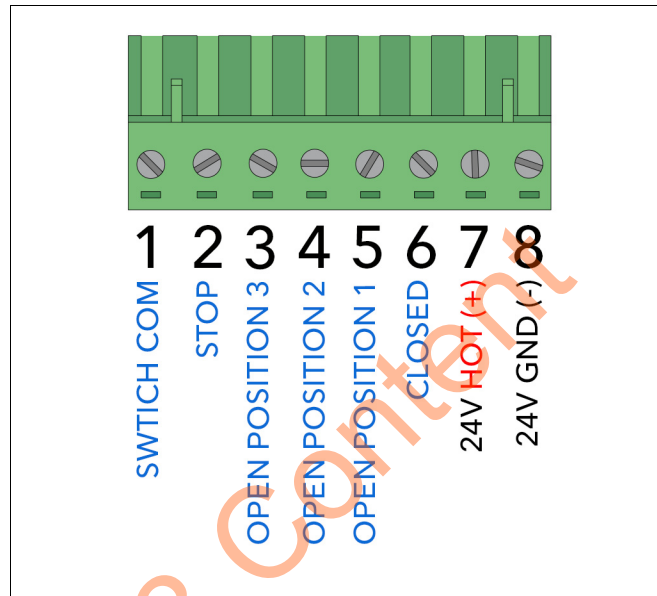

Figure 4

Terminal	Description
1	Common wire for optional wired switch
2	Stops window sash at current position
3	Position 3- defaults to 45 degree opening
4	Position 2- defaults to 20 degree opening
5	Position 1- defaults to 10 degree opening
6	Closes and locks the window
7	24V DC Hot (+) (1 Amp)
8	24V DC Ground (-)

2. Ensure the mating connector is reinstalled into the terminal block before applying power. Once power is on the unit, the lock motors will calibrate and move to a home position. The window can then be tested by pressing the “up” button on the small switch located near the control board. Pressing the “up” button will unlock and open the window. Pressing the “down” button will close and re-lock the window. The window will only open to about 4 inches when first powered. For maximum opening, recalibrate the window by pressing down and the reset/pair button simultaneously. See chart below.

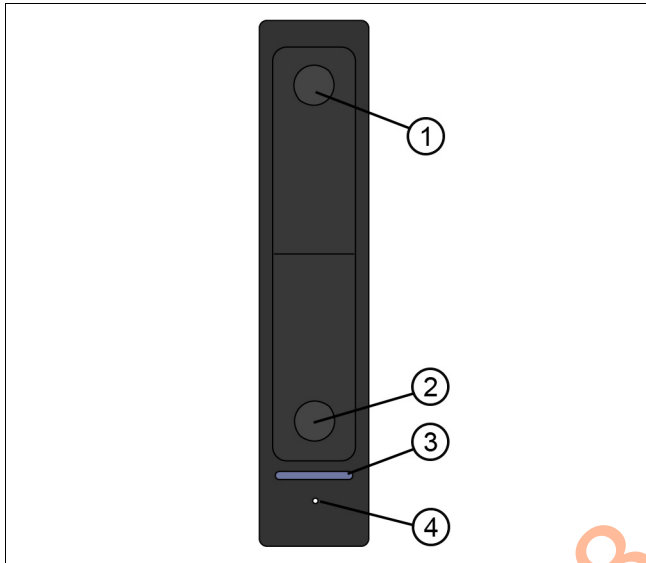

Figure 5

1	Up button, press once to open
2	Down button, press once to close and lock
3	Diagnostic LED
4	Reset/pair button (pinhole access)

**NOTE:** Reboot may fix any operational or WiFi connectivity issues.

**NOTE:** Factory reset: all WiFi information is deleted. The unit must be re-onboarded to WiFi if desired.

Button Press Functions	
Function	Button Press
Open to Max Position	Press the <b>"UP"</b> button once.
Open to Specific Position	Press and hold the <b>"UP"</b> button. (Pinch detection threshold is increased)
Close	Press the <b>"DOWN"</b> button once
Close and Lock	Press and hold <b>"DOWN"</b> button (pinch detection threshold is increased)
Reboot	Press "UP" 3x then "DOWN" 3x
Calibrate Motors to Find Max Open	Press "DOWN" + "RESET/PAIR"
Factory Reset	Hold "RESET/PAIR" button for 30 seconds

Diagnostic LED
Off = Normal
Alternating green/red = Calibrating motors
Pulse red 3x = Obstruction detected
Solid red = Power from supercaps
Pulse white = Sash is moving
Pulse blue = Moisture detected
Alternating blue/white = pairing mode

## Wire an Optional Switch

1. Wired switches control the window by temporarily connecting one of terminals 2-6 with the switch common on terminal 1 of the window controller. Any momentary switch rated for at least 3 volts and 25mA can be used. The window controller does not provide power to illuminate any switch LEDs.

*NOTE: The “common” terminal of a wall switch is connected to terminal 1 of the window. When a button of a wall switch is pressed and released, one of the connections between terminals 2-6 and terminal 1 is made, and the window takes action. The window only moves when the button is released and the controller senses the resulting rise in voltage on the corresponding wiring terminal.*

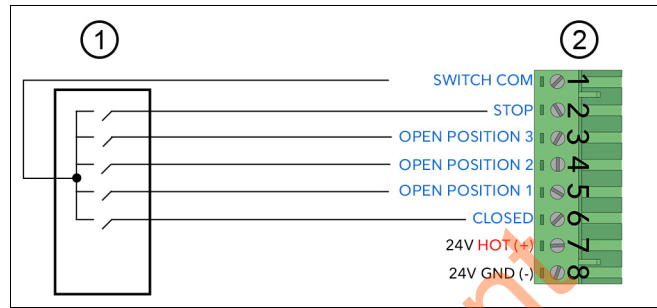

Figure 6

1	Wall switch
2	Window Terminals

## Switch Wiring Examples

1. **4 Button Switch Example:** This switch connects one of its 1-4 terminals to its “SC” terminal when the associated button is pressed. This will result in a switch that will control the window to 3 different open positions when pressing one of the top 3 buttons or to close and lock when pressing the bottom button.

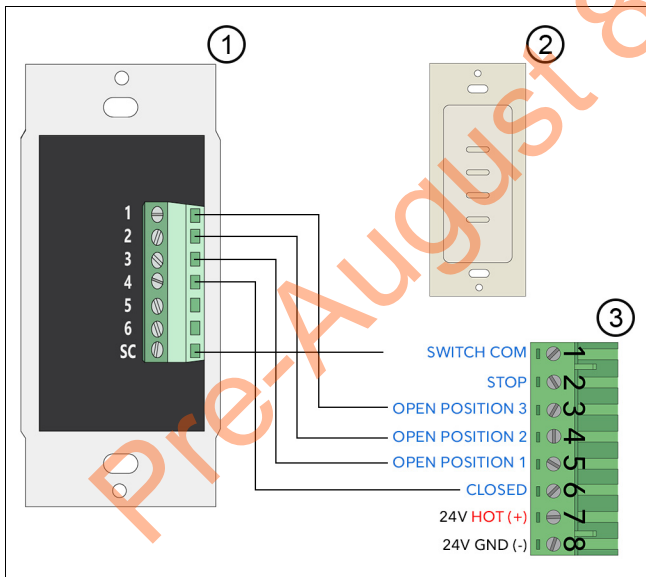

Figure 7

1	Low Voltage Switch Terminals (back)
2	Low Voltage Switch (front)
3	Window Terminals

2. **3 Button Switch Example:** This switch connects one of its 1, 2 or 4 terminals to its “SC” terminal when the associated button is pressed. This will result in a switch that will control the window to an open position when pressing the top button, stop the window when pressing the middle button or close and lock when pressing the bottom button.

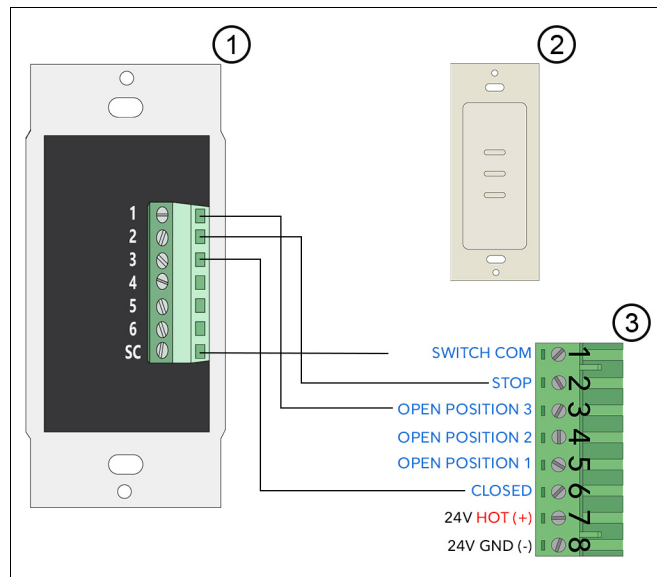

Figure 8

1	Low Voltage Switch Terminals (back)
2	Low Voltage Switch (front)
3	Window Terminals

## Wiring Multiple Windows to a Single Switch

1. This example shows three windows being wired to a single switch with 3 dry contact push buttons. Wired as shown, each of the top two buttons on the switch will open the windows to a different open position and the bottom button will close and lock the windows. There is no limit to how many window's dry contact terminals can be wired to a switch, but wire gauge will have an impact after about 1000 feet if the recommended Cat5e is used for the switch wire. The wiring shown is daisy chained from the terminals of one window to the next. This will result in the switch making the same contact closure for all windows simultaneously. Alternatively, a home run could be made to each window giving the flexibility to easily rewire the windows into different configurations at the switch in the future.

**NOTE:** If the windows wired to a single switch are of various sizes or types, the position to which they open will be slightly different due to various pivot points of the hardware.

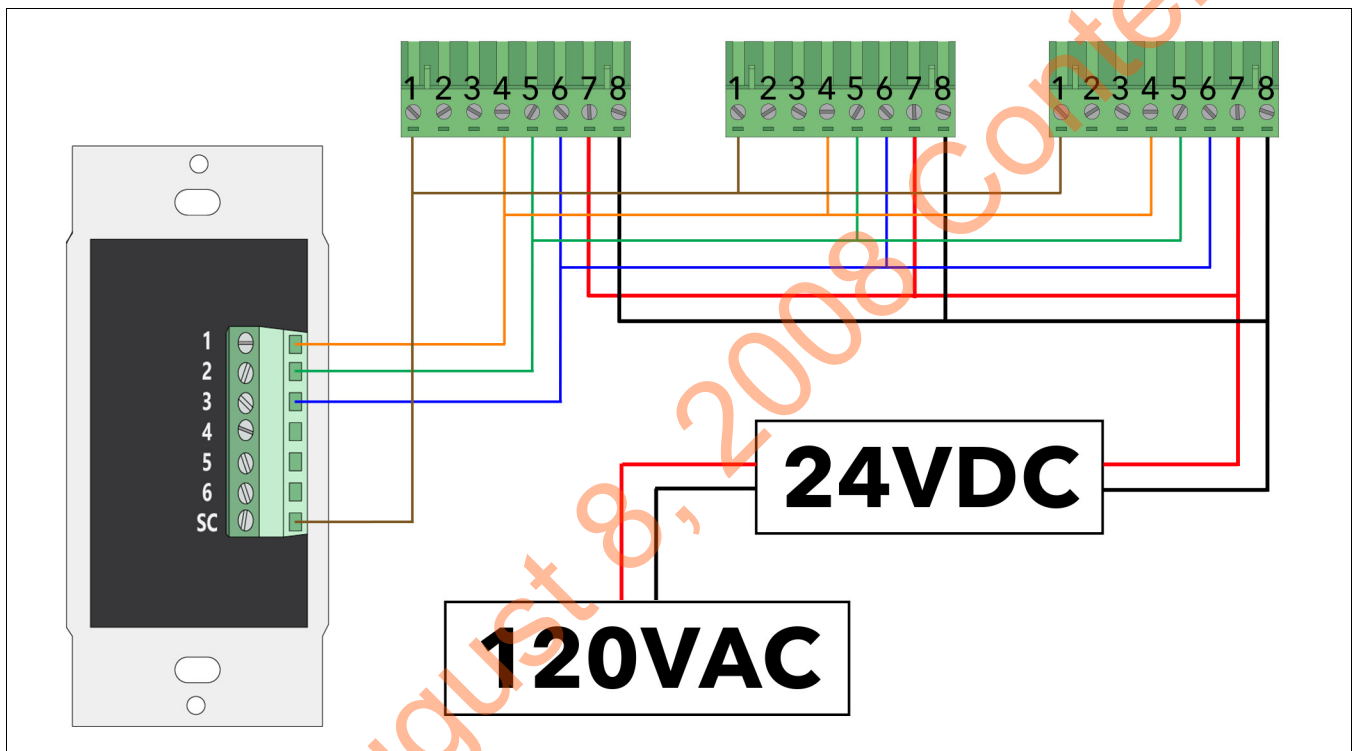

Figure 9

Switch Wiring Terminals	
Terminal	Description
1	Top Button
2	Middle Button
3	Bottom Button
4	Unused
5	Unused
6	Unused
SC	Switch common (all buttons short the wire coming into its terminal to SC)

Window Terminal Designations	
Terminal	Description
1	Common wire for optional wired switch
2	Unused
3	Unused
4	Position 2- defaults to 20 degree opening
5	Position 1- defaults to 10 degree opening
6	Closed- closes and locks the window
7	24VDC Hot (+) (1 Amp)
8	24VDC Ground (-)

# Marvin Power Supply

## ATTENTION

Each window requires 1 Amps at 24VDC. The voltage at the window must not exceed 26.5V. It is not required to use the power supply sold by Marvin. If a non-Marvin power supply is used, the power source must be a Class 2 type with limited voltage and current defined in Article 725 of the US National Electrical Code (NEC).

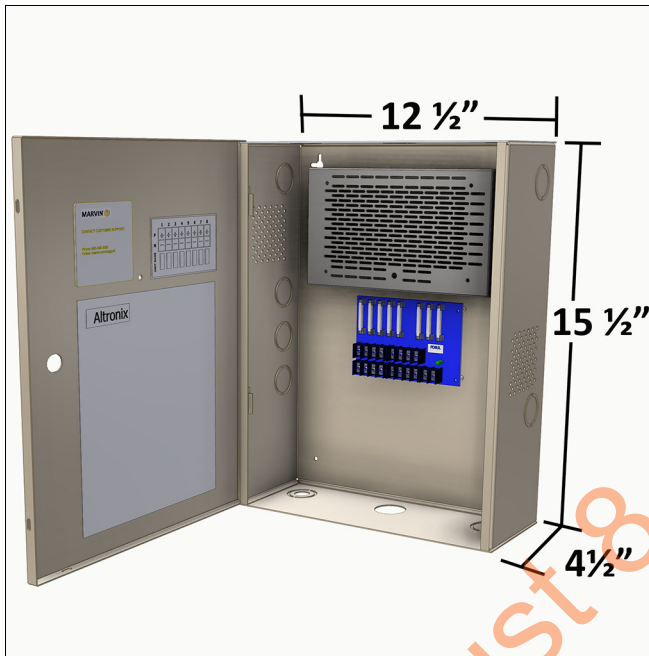

Figure 10 Wall mounted for indoor use. 1 1/8" and 1 3/8" combo knockouts. Provides 8 fused 24Vdc circuits. Product weight 9.5 lbs. Part Number: 02066143

The Marvin power supply has eight PTC fused terminals. Each terminal can support up to 2.5 amps of current. It is not recommended to connect more than three windows to a single terminal.